

# GinisED tools for spatial analysis of electric power supply network

Aleksandar Stanimirović<sup>1</sup>, Leonid Stoimenov<sup>2</sup> and Danilo Vulović<sup>3</sup>

**Abstract** – **GinisED is the geographic information system specially designed for electric power utility companies. GinisED was developed by CG&GIS Lab, Faculty of Electronic Engineering, University of Niš, and is deployed in ED Jugoistok Niš. A very important part of GinisED are tools for spatial analysis of electric power supply network, potential or actual events in electric power supply network and risk factors for a certain geographic area. In order to provide support for efficient spatial analysis we have developed a specific data model for representing electric power supply network in GinisED. Our data model is a combination of topological model (nodes and edges for representing geographic information) and typical graph data structure (for representing electric network attributes.**

**Keywords** –GIS, power supply network, spatial analysis, data model

## I. INTRODUCTION

Making decisions based on geography is basic to human thinking because geographic location is an important attribute of all human activities policies, strategies and plans. By understanding geography and people's relationship to location, we can make informed decisions about the way we live on our planet. Geographic information systems (GIS) are a special class of information systems that keep track not only of events, activities and things, but also of where these events, activities, and things happens or exist [1].

GIS enables capturing, storing, analyzing, and displaying geographically referenced information. It allows us to view, understand, query, interpret, and visualize data in a way that is quickly understood and easily shared. GIS technology can be used for scientific research, resource management, and development planning. Because geography location is very important for every day human activities, GIS solutions provide support for making decisions and solving many different problems: environmental monitoring, transportation management, public safety, facility security, disaster management, etc.

Management and visualization of underground utilities have been always of a great concern in many countries.

<sup>1</sup>Aleksandar Stanimirović is with the Faculty of Electronic Engineering at University of Niš, Aleksandra Medvedeva 14, 18000 Niš, Serbia, E-mail: aleksandar.stanimirovic@elfak.ni.ac.rs.

<sup>2</sup>Leonid Stoimenov is with the Faculty of Electronic Engineering at University of Niš, Aleksandra Medvedeva 14, 18000 Niš, Serbia, E-mail: leonid.stoimenov@elfak.ni.ac.rs.

<sup>3</sup>Danilo Vulović is with the Faculty of Electronic Engineering at University of Niš, Aleksandra Medvedeva 14, 18000 Niš, Serbia, E-mail: danilo.vulovic@elfak.ni.ac.rs.

Pipelines such as water supply, sewage, power supply, heat supply, industrial pipelines and communication lines, are essential infrastructures in cities. This tendency has been increased in the last decade while rebuilding and substituting existing principal pipelines to fit in with increased demands of citizens and industrial development. Moreover, newly designed underground pipelines for different purposes have been built along with various engineering projects. Insufficient, inaccurate and unclear information about the location and depth of cables and pipelines may cause various problems and may even result in tragic accidents [2].

Efficient functioning of utility companies engaged in the transmission and distribution of electricity cannot be achieved without proper record keeping and monitoring of the transmission and distribution network system [3]. Therefore, almost any electric power supply company has a need for the existence of specialized GIS solution that should provide mechanisms for collecting, storing and manipulating spatial data concerning transmission and distribution network system. This specialized GIS solution provides support for recording company assets, their locations their condition, how they are performing, and how much it costs to provide the service [4].

GIS tools for utility companies provide a very effective tool for generating maps and statistical reports from a database. However, GIS functionality far exceeds the purposes of mapping and generating reports. In addition to the basic functions related to automated cartography and data base management system, spatial analysis is the vital part of every GIS solution for utility companies. GIS is used to collect spatial data concerning distribution network, spatial analysis should be able to answer complex questions regarding space.

## II. RELATED WORK

The ability to take the geographic location of objects into account during search, retrieval, manipulation and analysis lies at the core of a GIS. How well these tasks can be accomplished is determined by the spatial data model. The starting point for modeling of geographic information is the geographic feature. A feature is an abstraction of a real world phenomenon. A geographic feature is a feature associated with a location relative to the Earth. A digital representation of the real world can be thought of as a set of features [5].

Among many of the commonly used GIS data models, simple features model has the most simple data structure. Every geographic feature has a unique persistent ID, set of thematic attributes (represented as alphanumeric data) and a number of geometric attributes. In this model, feature geometric attributes are limited to simple geometries. Simple geometries are defined as 2-dimensional geometries and linear

interpolation is used for curve representation. Basic geometry types are points, lines and polygons [5].

Another model commonly used in GIS is the topological model [1]. Topological features are simple features structured using certain topological rules. Introduction of topological relations between features simplifies data validation, modeling behavior of connected objects and optimization of different spatial analysis. The network model is just a special case of the topological model. The network data structures are used for modeling flows. Tree structure is used to model the radial network, while the graph structure is used to model cyclic networks. As new elements, topological model introduces nodes and edges. A node is a distinguished point that connects one or several arcs. An edge is a line composed by a start and an end node. The advantage of this model is the topological information it is containing: every object includes information about the elements it is related to.

Database management systems are vital part of every modern operational GIS [1]. DBMS solutions provide GIS with standardized approaches for storing and, more importantly, accessing and manipulating geographic data using some standard query language. GIS provides the necessary tools to load, edit, query, analyze, and display geographic data. Innovative work in the GIS field has extended standard relational DBMS solutions with specialized support for storing and managing geographic data.

There have been several attempts to define a standard for representing and processing geographic data in relational databases. The GIS community, working under supervision of ISO and OGC boards, has defined the core geographic types and functions to be used in a relational DBMS and accessed using the SQL language [6].

### III. GINISED – GIS FOR ELECTRIC UTILITY

GinisED is the geographic information system specially designed for electric power utility companies. It uses the most modern GIS technologies and methodologies for collecting, editing, visualization and analysis of spatial electric power supply network data. GinisED was developed by CG&GIS Lab, Faculty of Electronic Engineering, University of Niš, and is deployed in ED Jugoistok Niš (Serbian public electric power supply company). GinisED helps ED Jugoistok Niš in everyday operation and maintenance as it provides the accurate, reliable spatial and non-spatial information to the utility operational staff, and in turn help them better meet customer needs [7][8].

GinisED (Figure 1) tools can be divided into three groups [4][5]:

- Tools for collecting (digitization, map scanning and vectorization using GPS and other specialized equipment) and editing the spatial electric power supply network data.
- Tools for visualization of spatial electric power supply network data for a certain geographic area.
- Tools for spatial analysis of electric power supply network, potential or actual events in electric power supply network and risk factors for a certain geographic area.

Basic components of the GinisED system are (Fig. 1):

- *Centralized geospatial database* for storing data about electric power supply network. Elements of electric power supply networks are stored as a collection of geobjects. Each geobject is presented by its spatial component (coordinates or geometry) and thematic component (e.g. parameters for the conductors and protective devices such as voltage level, conductor type, length, construction and device type).
- *GinisED Editor* is a specialized tool for geographic editing of distribution network. It is a desktop application developed in accordance with carefully studied needs and requirements of customers. It is used for creation and editing of geographic schemes of the network, editing parameters of network elements and their connectivity.
- *GinisED Web* is a WebGIS application that allows quick and easy positioning on a specific geographic area, search and selection of parts of electric power supply networks. This application implements information integration functionalities and uses data from centralized geospatial database.
- *WMS [9], WFS [9] and custom Web Services* are components that provide GinisED Web and GinisED Mobile Server with raster maps and information considering geo-objects. WMS and WFS are components built according to Open Geospatial Consortium specifications. Custom Web Services are used for data integration and enable GinisED Web with searching and reporting capabilities.
- *GinisED Mobile Editor* is tool for GPS survey of electrical consumers and relevant electrical assets. *GinisED Mobile Server* supports mobile GIS applications and provides map segments and synchronisation between mobile database and centralized geospatial database.

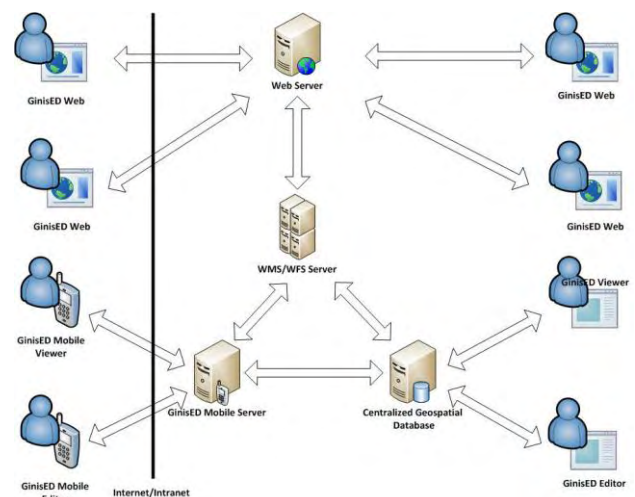

Fig. 1. GinisED architecture

### IV. MODEL FOR REPRESENTING POWER DISTRIBUTION NETWORK

In order to provide support for efficient spatial analysis we have developed a specific data model for representing electric power supply network in GinisED. Power distribution network usually contains features with line geometry (power

cables of different types) or point geometry (substations, poles, street lights, etc.). The GinisED system provides 2D visualization of all the elements of the power distribution network (Fig. 1). The major trace of power cables is mostly the same, i.e. under the streets, which results in overlapping lines. To avoid this overlap, in visualization we offset the multiple power cables to increase the readability of the map (schematic view).

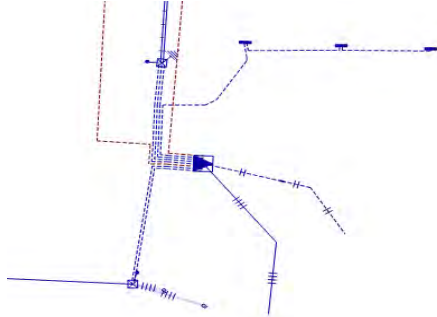

Fig. 2. 2D visualization of power distribution network (schematic view)

In order to represent specifics of power distribution network we have designed GinisED network model (Fig. 3). GinisED data model is a combination of topological network model (nodes and edges for representing geographic information) and typical graph data structure (for representing electric network attributes). The core part of GinisED network model is based on our GinisFrame object-oriented model for representing geographic features.

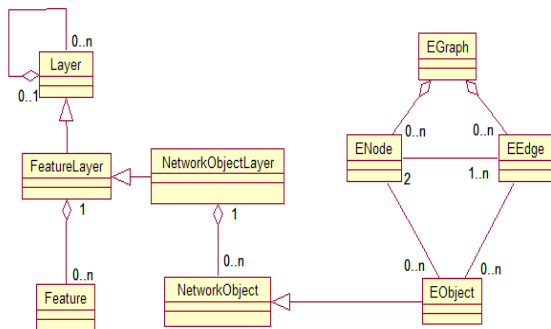

Fig. 3. The GinisED network model

Layer, FeatureLayer and Feature classes are derived from the original GinisFrame object model. These three classes define the basic organization of geographic information in GinisED system. Layer class is a basic organizational structure of our network model. Different layers can be organized in a hierarchical structure, thus providing a hierarchy and aggregation of geographic features. The FeatureLayer class defines layers of simple features (Feature class). This model is extended with NetworkObject class for network features and NetworkObjectLayer class for appropriate layers. Network objects, as opposed to simple features do not contain explicitly defined geometry. The geometry of the network features is indirectly contained in topological graph (Fig. 3).

EGraph class implements topological graph that defines geometry of power network elements. EObject class

implements power network elements and contains all thematic attributes. Geometry of power distribution network is defined through nodes (point geometry) and edges (line geometry). Additionally, every node element contains connection matrix that defines electrical connections between elements of power distribution network (Fig. 4).

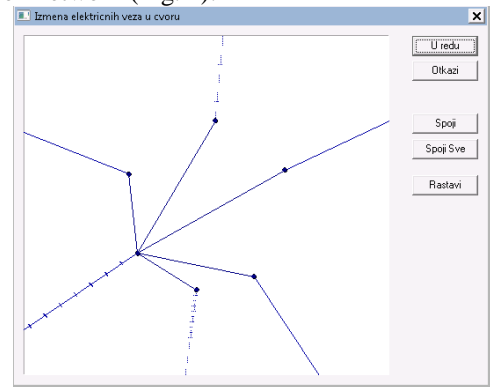

Fig. 4. Electrical connections in node

GinisED system uses centralized geospatial database for storing data about electric power supply network. This database is implanted using Oracle DBMS (Fig. 5). Each network feature on a map is stored as one logical record in EOBJECT table. A topological part of our model is stored in relational database using Oracle Spatial geometry model. Oracle Spatial geometry model has several simple geometry types and collections of them. One of the benefits of using Oracle spatial data types is that a quite extensive number of spatial queries can be performed at database level. In most scenarios spatial relationships of geometries such as “nearest to”, or “within a specified region” are needed. Using this mechanism, queries which can be formulated as “is a cable at a particular distance from a cadastral parcel” or “find the nearest buildings and their distance to a specific cable” or “find all underground networks in a given region” can be performed.

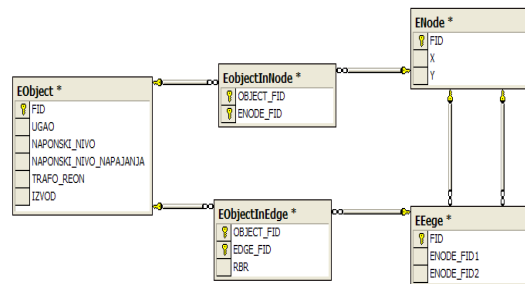

Fig. 5. GinisED geospatial database

## V. GINISED TOOLS FOR SPATIAL ANALYSIS

Tools for spatial analysis are one of the most valuable parts of GinisED system. Creating making maps alone and generating standard statistics reports does not justify the high cost of building a GIS. The greatest strength of GinisED system is possibility to utilize various types of information in

the spatial context and to generate new information and conclusions on the basis of this analysis.

A very important part of GinisED are tools for spatial analysis of electric power supply network, potential or actual events in electric power supply network and risk factors for a certain geographic area. Spatial analysis in GinisED involves two types of operations: attribute query (also known as non-spatial query) and spatial query. Attribute query requires the processing of attribute data without referencing spatial information. Spatial query involves selecting features based on location or spatial relationships, which requires processing of spatial information.

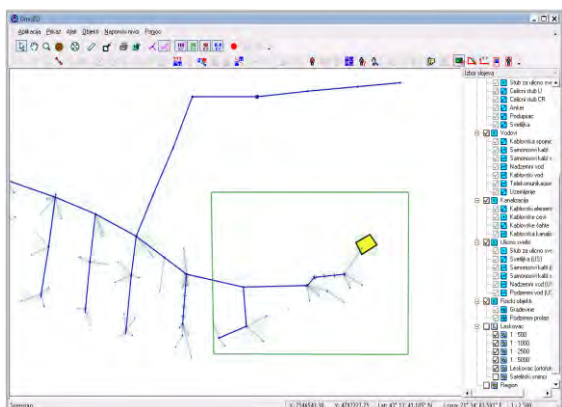

Fig. 6. Spatial query: Find all network elements in specified region

GinisED provides simple point-and-click query capabilities and sophisticated queries, analysis and display functions using visual, user-friendly techniques (Fig. 6). GinisED provides timely information and decision making support to GIS users. It helps users to solve problems, analyze geographic situations, extract necessary data and generate new information.

While basic spatial analysis involves some attribute queries and spatial queries, complicated analysis typically require a series of GIS operations including multiple attribute and spatial queries, alteration of original data, and generation of new data sets. In order to support effective spatial analysis GinisED provide powerful query builder that can combine different types of attribute queries and spatial queries.

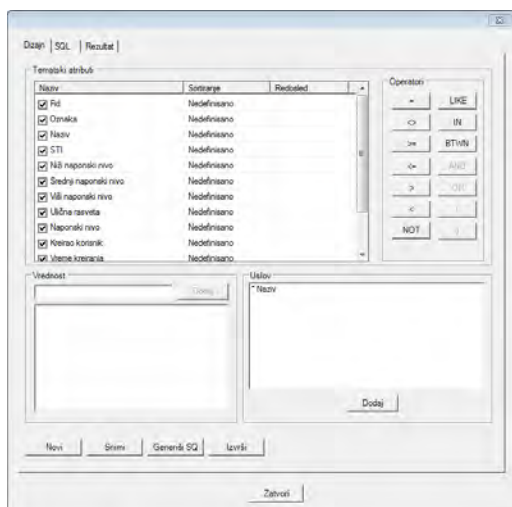

Fig. 7. GinisED Query builder

## VI. CONCLUSION

Development of GinisED system for ED Jugoistok Niš started in 2004. Before GIS was implemented, data maintenance was erratic and time-consuming. Keeping track of changes was difficult because hard-copy maps or digital CAD drawings were shared among the utility's different departments.

For the past six years implemented GIS solution has improved efficiency in overall company operations. GinisED quickly became an essential part of the ED Jugoistok Niš day-to-day business. Today, GinisED is considered very important data resource for the distribution analyses as it contains most facility information including major network topological structures. The circuit map display provided by the GinisED system is the most natural graphic user interface for engineers. In some applications, such as the trouble call analysis, geographic maps provide more information to engineers than the traditional one-line diagrams.

## REFERENCES

- [1] P. A. Longley, M. F. Goodchild, D. J. Maquire, D. W. Rhind, *Geographic Information Systems and Science*, ISBN 978-0470721445, Wiley, 3rd ed., 2010.
- [2] S. Zlatanova, F. Döner, P. van Oosterom, "Management and visualization of utility networks for local authorities: a 3D approach" *Electronic Government and Electronic Participation, Joint Proceedings of Ongoing Research and Projects of IFIP EGOV and ePart, Schriftenreihe Informatik 37*, Trauner Verlag, pp. 459-474, 2011
- [3] D. Pickering, J. M. Park, D. H. Bannister, 1993, "Utility Mapping and Record Keeping for Infrastructure", *Urban Management and Infrastructure - Urban Management Programme*, Washington, D.C., Vol. 10, pp. ix-11.
- [4] J. I. Igbokwe, E. J. Emengini, "GIS in Management of Electricity Distribution Network: A case study of Onitsha-North L.G.A., Anambra state, Nigeria", [http://www.gisdevelopment.net/application/utility/power/utility\\_p0022pf.htm](http://www.gisdevelopment.net/application/utility/power/utility_p0022pf.htm) , accessed 12.01.2011
- [5] OpenGIS Reference Model (Version 0.1.3), document 03-040, Open Geospatial Consortium, Wayland, Mass., [http://portal.opengeospatial.org/files/?artifact\\_id=3836](http://portal.opengeospatial.org/files/?artifact_id=3836), March 2003.
- [6] OpenGIS Simple Feature Specification for SQL (Revision 1.1), document 99-049, Open Geospatial Consortium, Wayland, Mass., [http://portal.opengeospatial.org/files/?artifact\\_id=829](http://portal.opengeospatial.org/files/?artifact_id=829), March 2003.
- [7] A. Stanimirović, D. Stojanović, L. Stoimenov, S. Đorđević-Kajan, M. Kostić, A. Krstić, "Geographic Information System for Support of Control and Management of Electric Power Supply Network", *Proceedings of IX Triennial International Conference on Systems, Automatic Control and Measurements SAUM*, ISBN-86-85195-49-7, Niš, 2007.
- [8] L. Stoimenov, A. Stanimirović, N. Davidović, M. Bogdanović, A. Krstić, D. Nikolić, "GinisED Enterprise GIS - Framework for the Utility of the Future", *CIRE2011*, Frankfurt, Germany, 6-9. June, ISSN:2032-9644, [www.cired2011.org](http://www.cired2011.org)
- [9] Open Geospatial Consortium, WMS and WFS Specifications, 2002, <http://www.opengeospatial.org/>