

Energy Efficiency of Wireless Sensor Networks

T. R. Nikolić, G. S. Nikolić, M. K. Stojčev, B. D. Petrović, G. S. Jovanović*

Abstract – Wireless sensor network includes a large number of simple sensor nodes that consist of sensor, microcontroller and transceiver block. Sensor nodes usually operate with non-rechargeable batteries so that the power consumption becomes a very important issue in the development of these networks. The main goal of this paper is to reduce power consumption of sensor nodes and extend the lifetime of batteries. The total power consumption of a sensor node is evaluated in real application conditions by using information from datasheets for all its blocks. Simulation results show that power-gating technique is superior in respect to power-saving, especially in the case when lower duty-cycling is implemented.

Keywords – Wireless sensor networks, Energy efficiency, Power-saving, Power-gating.

I. INTRODUCTION

Low-power wireless system is constituent of many contemporary applications. It includes a number of wireless sensor nodes that collect information from external environment with sensors, then process the information, and communicate with other neighboring nodes in the network. Such system has to operate for an extended period of time with only a limited power source available, and is usually constrained to a limited size (i.e. small battery could be used) [1]. For most situations the use of rechargeable batteries is not a realistic option. For instance, buried nodes used in wireless underground sensor networks and nodes embedded inside the walls of buildings, in the roads, or in the internal structures of a bridge, typically cannot employ rechargeable batteries [2]. Therefore, the main goal is to extend as much as possible the lifetime of non-rechargeable batteries.

Two design areas can be exploited in order to increase the lifetime of a battery: networking protocols and power management. The focus of this work is on the specific power management techniques. They provide an efficient energy solution for wireless sensor network (WSN) nodes that are powered by non-rechargeable batteries.

We identified two power management aspects that allow a significant extension of the battery lifetime [2]:

1) The conventional power-saving approach is based on setting the standby pin (sometimes called shutdown or power save). The majority of the blocks in a WSN node have some sort of standby pin. However, such control cannot effectively switch off all the internal circuitries of the module. The quiescent current for the power-saving mode is small but still higher than 1 μA .

T. R. Nikolić, G. S. Nikolić, M. K. Stojčev, B. D. Petrović, G. S. Jovanović, are with the Faculty of Electronic Engineering, Niš, Serbia.

2) The power-gating technique is based on the introduction of an electronic switch between an electronic module or chip and the power-supply line. It can be applied in WSNs as a way to save energy for both active and sleep modes of a device [3]. Therefore, it is possible to temporarily shut down blocks of circuitries that are not in use. For instance, while the sensor node is taking measurements usually, the radio transceiver is not required and it can be turned off.

By using power-saving, the module can quickly return to normal operation as soon as the standby pin returns to disabled mode. The main disadvantage of the power-gating technique is the delay caused by completely turning off/on a device (can be as high as 1 s). However, if this delay is not so critical for a given WSN application, a significant energy reduction can be achieved by means of power-gating.

In this paper we estimate the energy consumption of the wireless sensor node in real application conditions by using information from datasheets for all its building blocks (microcontroller, sensor and transceiver), for both mentioned power management techniques. Next to that, we show in what cases it is justified to use power-gating technique in order to extend the lifetime of batteries.

The rest of the paper is organized as follows. Section two considers energy consumption of a wireless sensor node and techniques for its reduction. Section 3 gives brief description of activities of sensor node in real applications. Experimental results are presented in Section 4. Concluding remarks are given in Section 5.

II. STRUCTURE OF SENSOR NODE FROM ENERGY CONSUMPTION POINT OF VIEW

A low-power wireless system comprises a number of wireless sensor nodes, and each node consists of several functional blocks. The Fig. 1 shows a simple architecture of a typical wireless sensor node which is used in many applications. In our current design, the energy source is a battery (energy harvesting unit can be used in future design). The power management unit generates the required supply voltages and handles power allocation of all functional blocks within node. The sensor block collects information about the conditions in the environment and generates data which is processed by a microcontroller. The transceiver block sends/receives data to/from the access point or neighboring wireless sensor nodes. In addition, the microcontroller handles with switching on/off the various functional blocks, processes the sensed data, and drives the transceiver.

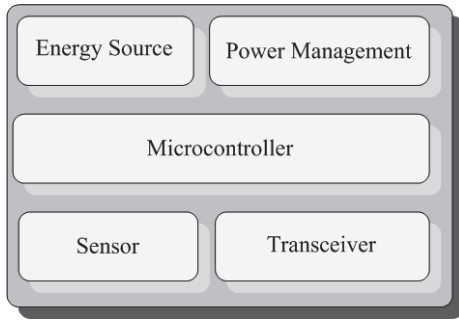

Fig. 1. Block diagram of a low-power wireless sensor node

The three main ways in which wireless sensor node consumes energy are sensing, communication and data processing. For each unit of useful work it performs, the node consumes different amount of energy. In a low-power wireless sensor node shown in Figure 1, all the functional blocks must be carefully specified and designed to minimize the total system power. In terms of consumption of sensor node, we consider a processor, a sensing module, and a radio transceiver. These blocks can be in active or inactive (sleep) state. Therefore, for one beacon period, T_{BP} , we define the time interval during which the sensor node is active as T_{ON} , and the time interval during which the sensor node is inactive (sleep) as T_{OFF} .

At the beginning, in order to estimate energy consumption, we consider the following scenario. The sensor node periodically wakes up, performs some processing (10% of time T_{ON}), takes measurements (50% of time T_{ON}), sends/receives data to/from the neighboring node (30% of time T_{ON}), performs more processing (10% of time T_{ON}), and finally sleeps again (time T_{OFF}). In such node we apply two power management techniques: a) the power-saving technique, that is, the use of standby/sleep pins already available at the sensing and radio modules, and b) the power-gating technique, implemented externally. It is assumed that the power source (e.g., batteries) is directly connected to the devices, that is, no additional loss due the existence of a voltage regulator or DC-DC converter. Table 1 shows the values for the power consumed in each task/state that are based on off-the shelf analog switches and modules used in wireless sensor nodes [2].

TABLE 1
POWER PROFILE FOR A WSN NODE

	Microcontroller	Sensor	Transceiver
Active (regular operation)	5 mW	30 mW	350 mW
Inactive (power saving)	2 μ W	5 μ W	20 μ W
Inactive (power gating)	2 μ W	1 μ W	1 μ W

Researches show that even at low radio on-time operation (radio on-time, or duty-cycle, is approximately 1-2%) the energy needed for communication is about an order of magnitude more expensive that all other operations combined [4]. From Table 1 we can conclude that the wireless transceiver consumes the highest power in active and inactive

(power saving) state in respect to the other blocks. In inactive state with applying power gating technique the power consumption of the transceiver block is significantly reduced.

During simulation, we consider and compare three cases:

- 1) Active mode – all constituents of the sensor node are active during the time interval T_{ON} , while during the time interval T_{OFF} they switch to power-saving mode;
- 2) Power-saving mode – each constituent of the sensor node is active during part of T_{ON} , only, when it is addressed, and after that enters into power-saving mode for the rest of T_{ON} and T_{OFF} ;
- 3) Power-gating mode – each constituent of the sensor node is active during part of T_{ON} , only, when it is addressed, and after that enters into power-gating mode for the rest of T_{ON} and T_{OFF} .

Total energy consumption is calculated as the sum of energy consumption in the active state and the idle (sleep) state, taking into account all the blocks of the sensor node

$$E_{total} = E_{active} + E_{idle/sleep} = E_{sen} + E_{mcu} + E_{transc} + E_{idle/sleep} \quad (1)$$

Simulation results shown in Figure 2 present the total energy consumption levels for one year period in respect to different application duty cycles (expressed as number of measurements per day), for three mentioned cases. The total energy consumption per year for the power-saving mode is calculated as the sum of the active and the inactive (power-saving) values. For the power-gating mode, similarly, it is the sum of active and the inactive (power-gating) values. For calculation of energy consumption per year, the values for the consumed power, presented in Table 1, are used.

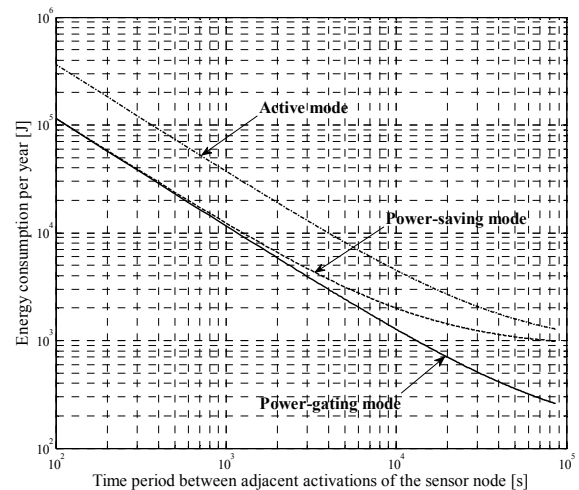

Fig. 2. Total energy consumption for three cases

As can be seen from Fig. 2, energy consumption is reduced by applying both power management techniques. Power-gating technique is superior with respect to power-saving technique when the number of sensor node activations is reduced. In general, for all three cases, as the duty cycle decreases the energy consumption decreases, too. For example, in the case of power-gating mode, when

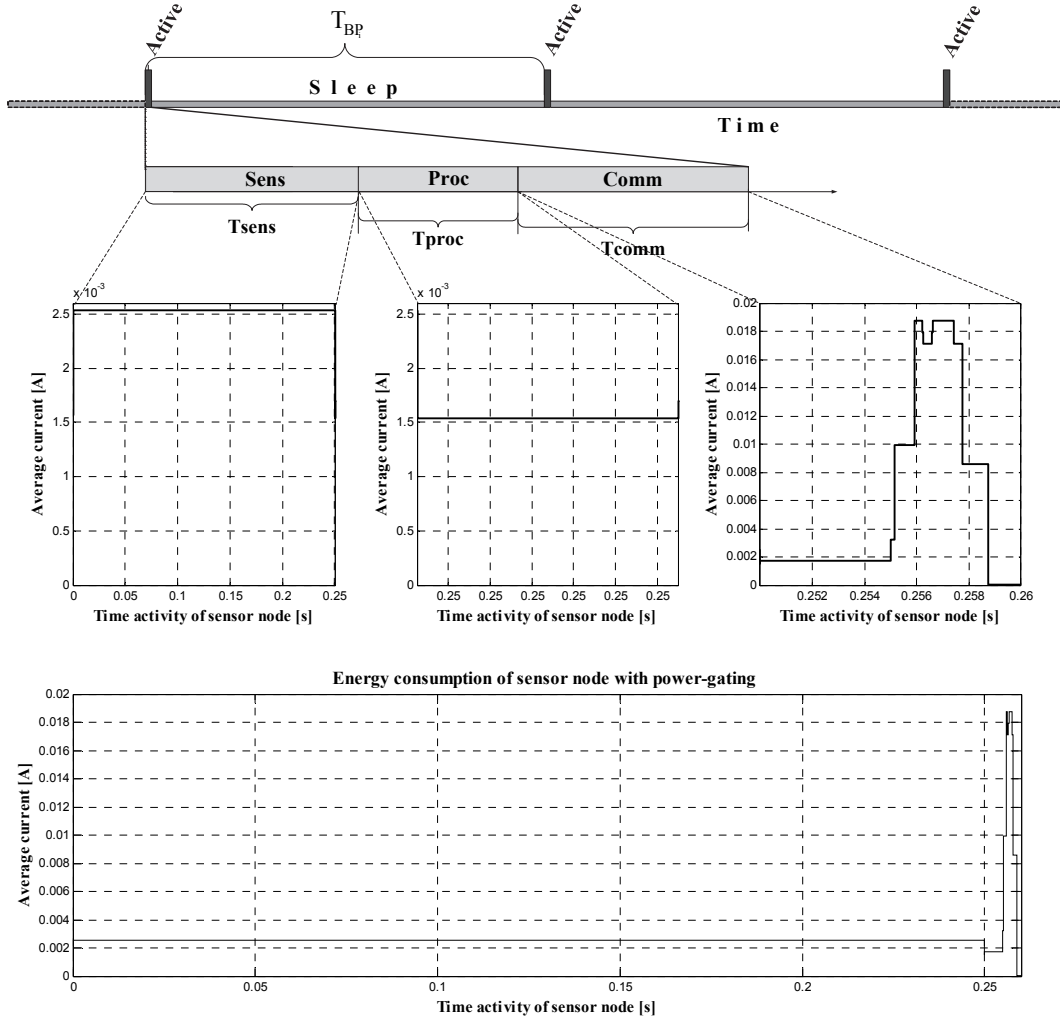

Fig. 3. Activity profile of the sensor node

the sensor node enters into active mode every 100 s the energy consumption is approximately 10^5 J, while it enters into active mode one times per day the energy consumption is approximately $2 \cdot 10^2$ J. This implies that three order of magnitude of reduction in energy consumption can be achieved.

III. ACTIVITY PROFILE OF THE SENSOR NODE

Our goal now is to verify the energy consumption of the sensor node in real applications by using information from data sheets for all its constituents. During the conducted analysis all three cases will be considered. Figure 3 shows the typical activity profile of the sensor node during single beacon period, T_{BP} , which corresponds to the sum of T_{ON} and T_{OFF} . During active state (Fig. 3) three sequential activities are performed, sensing, data processing, and communication. The sensing activity is responsible for information collection and analog-to-digital conversion. The energy consumption during this activity comes from multiple operations, including power-on (-off) switching of sensor elements, signal sampling, and analog-to-digital conversion. We use the LM75 temperature sensor [5] for which the switching-on time is 125 ns, and the conversion time is 250 ms. Data processing activity includes

power management, processing of sensed data and handles execution of protocol subroutines. For our design the microcontroller MSP430FR5969 [6] is used. It is involved in all the activities of the wireless sensor node. The communication activity includes several states that are presented in Table 2. In our design within the transceiver block, a CC110L [7] component is used.

TABLE 2
STATES OF TRANSCIVER BLOCK

State name	Activities	Duration
Start-up	powering-on the digital part and start local oscillator	150 μ s
Synthesizer-on	turning-on the freq. synthesizer	750 μ s
TX-RTS	transmit mode, sending RTS	320 μ s
Turn around	TX to RX switching	30 μ s
RX-CTS	receive mode, receiving CTS	320 μ s
Turn around	RX to TX switching	30 μ s
TX-DATA	transmit mode, sending DATA	800 μ s
Turn around	TX to RX switching	30 μ s
RX-ACK	receive mode, receiving of ACK	320 μ s

In order to achieve reduction in energy consumption in a sensor node operation, in our design with data from datasheets, we propose using two techniques, power-saving and power-gating. Power-saving approach is based on using standby pin for switching on/off the sensor node architecture between active and sleep state. In this case, the average current at a given supply voltage (power consumption) in sleep state corresponds to value from datasheet for each block of the sensor node. Power-gating approach uses load switches for switching on/off the sensor element and the transceiver block with the aim to switch-off the leakage currents of inactive elements. As load switch TPS22908 [8] is used. In this case, the quiescent current for this load switch is used as average current in sleep state.

IV. EXPERIMENTAL RESULTS

In order to verify our proposal, we have conducted an analysis for all three mentioned cases. The simulation is carried out by using Matlab tool. With aim to calculate the energy consumption for all constituents of the sensor node, individually, data from the datasheets relating to the average current are used. The supply voltage of 3V is used. The total energy consumption is calculated for one year period in respect to different measurement frequency. Simulation results in Matlab tool, for active, power-saving and power-gating mode, are presented in Fig. 4.

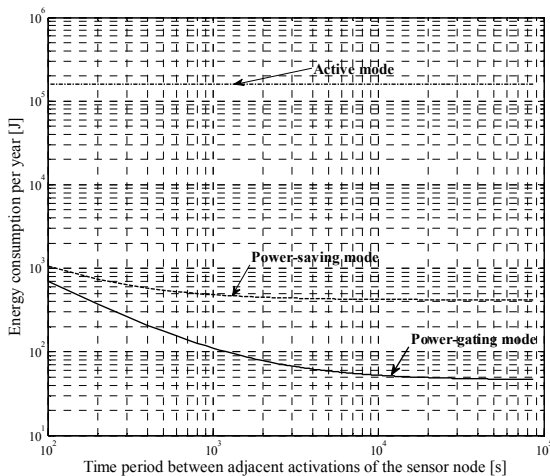

Fig. 4. Total energy consumption in real conditions

By analyzing Fig. 4 we can conclude the following:

1) In general, for both power-saving and power-gating technique, as the time period between two measurements increases the energy consumption decreases, but this reduction is more pronounced in power-gating. For example, in the case of power-gating mode, when the sensor node performs measurement every 100 s the energy consumption is approximately 800 J, while for measurements one times per day the energy consumption is approximately 50 J. This implies that the reduction of 16 times can be achieved.

2) Power-gating technique is superior with respect to the power-saving technique, for any period of measurement. For example, when the sensor node is activated at every 10^3 s, the

energy consumption is approximately 100 J when power-gating is implemented, and 500 J for power-saving, while for active mode is about $1.7 \cdot 10^5$ J.

V. CONCLUSION

Nowadays, WSNs are widely used in many applications due to number of advantages such as reduced cost and flexibility. However, energy consumption in wireless sensor nodes with non-rechargeable batteries is very important issue. In this paper we have presented two energy efficient techniques that can be used in order to extend the lifetime of batteries. For both techniques we have estimated the energy consumption of all building blocks of the wireless sensor node. With aim to show a justification of utilization of the power gating technique in real applications we have conducted analysis by using information from datasheets. Simulation results show that the energy consumption of the sensor node is significantly decreased when power-gating technique is implemented (one order of magnitude in regard to power-saving). The obtained results provide the sensor node designer to make a correct choice which relate to the power management technique and selection of beacon time.

ACKNOWLEDGEMENT

This work was supported by the Serbian Ministry of Education and Science, Project No TR-32009 – "Low power reconfigurable fault-tolerant platforms".

REFERENCES

- [1] A. Burdett, "Ultra-Low-Power Wireless Systems: Energy-Efficient Radios for the Internet of Things", *IEEE Solid-State Circuits Magazine*, vol. 7, no. 2, Spring 2015, pp. 18-28.
- [2] A. Silva, M. Liu, and M. Moghaddam, "Power-Management Techniques for Wireless Sensor Networks and Similar Low-Power Communication Devices Based on Nonrechargeable Batteries", *Journal of Computer Networks and Communic.*, 2012, Art. ID 757291, 10 pages.
- [3] M.A. Pasha, S. Derrien, and O. Sentieys, "Toward Ultra Lowpower Specialization of a Wireless Sensor Network Node", *IEEE 13th International Multitopic Conference (INMIC'09)*, pp. 1-6, Islamabad, Pakistan, December 2009.
- [4] S. Aggarwal, and R. Rani, "A Review of Fault Detection Techniques for Wireless Sensor Networks", *International Journal of Computer Science Issues (IJCSI)*, July 2013, vol. 10, issue 4, no. 1, pp. 127-138.
- [5] Maxim Integrated, Datasheet for Digital Temperature Sensor and Thermal Watchdog with 2-Wire Interface, available at <https://datasheets.maximintegrated.com/en/ds/LM75.pdf>, (accessed March 2017)
- [6] Texas Instruments, datasheets for MSP430™ ultra-low-power Microcontrollers, <http://www.ti.com>, (accessed March 2017)
- [7] Texas Instruments, datasheet for Value Line Transceiver CC110L, available at <http://www.ti.com/product/cc110L>, (accessed March 2017)
- [8] Texas Instruments, Low Ron Load Switch, <http://www.ti.com/lit/ds/symlink/tps22908.pdf>