

System for Flight Control and Technical Condition of Unmanned Aerial System

Krume Andreev¹, Ivo Dochev² and Rumen Arnaudov³

Abstract – For unmanned aerial systems (UAS) to be successfully deployed and integrated into the national airspace, it is imperative that they possess the capability to effectively complete their missions without compromising the safety of other aircraft, as well as people and property on the ground. This necessity creates a natural requirement for UAS that can respond to uncertain environmental conditions and emergent failures in real-time, with robustness and resilience close enough to those of manned systems. This report introduce a system that meets this requirement with the design of a real-time on-board system for flight control and technical condition capability to continuously monitor sensors, software and hardware components. This system can detect and diagnose failures and violations of safety or performance rules during the flight of a UAS.

Keywords – UAS, Unmanned aerial systems, Technical condition, Multi-purpose development platform.

I. INTRODUCTION

In the last decade has seen a rapid development of unmanned aerial systems (UAS). Companies producing this type of aircraft equipment continuously strive to improve and develop new ones with improved functional parameters. UASs can be used only if they can effectively complete their mission and respond to the problems and uncertain environmental conditions. They should always keep safety in relation to other aircraft, to people and property on the ground.

Extremely important is the development and the need to develops systems and algorithms for flight control and technical condition of the UAS. It is important to provide a method for developing and implementing, a powerful system operating in real time on the board of a UASs, hardware combined with software systems and sensors for the management of the technical condition of unmanned aircraft [1].

This report shows the architecture of a system for flight control and technical condition of the UAS, built using a Multi-purpose development platform.

¹Krume Andreev Ph.D. student is with the Faculty of Telecommunications at Technical University of Sofia, 8 Kl. Ohridski Blvd, Sofia 1000, Bulgaria, E-mail: andreev.k@abv.bg

²Ph.D. Ivo Dochev Assoc. Prof. is with the Faculty of Telecommunications at Technical University of Sofia, 8 Kl. Ohridski Blvd, Sofia 1000, Bulgaria, E-mail: idochev@tu-sofia.bg

³Ph.D. Rumen Arnaudov Professor is with the Faculty of Telecommunications at Technical University of Sofia, 8 Kl. Ohridski Blvd, Sofia 1000, Bulgaria, E-mail: ra@tu-sofia.bg

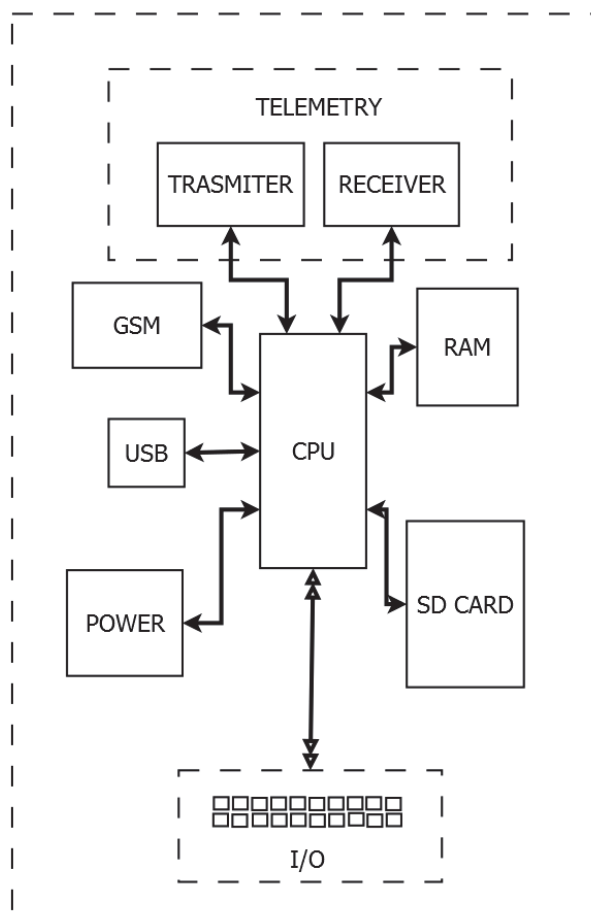

Fig. 1. Architecture of a multi-purpose development platform

II. ARCHITECTURE OF A SYSTEM FOR THE CONTROL OF FLIGHT AND TECHNICAL CONDITION

A. Multi-Purpose Development Platform for Collecting and Processing Data

Fig. 1 shows the architecture of Multi-purpose development platform. It is characterized by a high degree of integration. It is built based on a system on a chip (SoC), including in himself all the basic building blocks of modern computer systems - a central processing unit (CPU), memory (RAM), GSM module, telemetry, card reader (SD), universal serial interface (USB), digital inputs and outputs of a general purpose (I/O). Telemetry and GSM module enables the multi-purpose development platform to connect to the ground

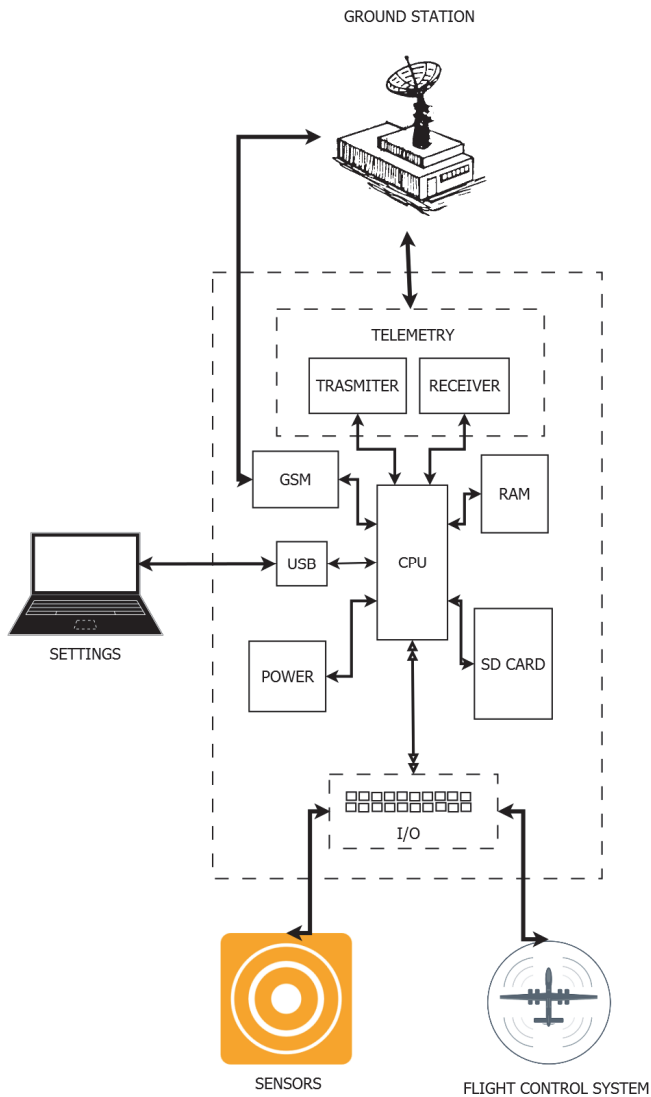

Fig. 2. Multi-purpose development platform

station and sending messages. The card reader is designed to carry the appropriate memory card, on which is installed on the operation system of the platform. USB ports may be used to connect different compatible devices for settings: a computer mouse, keyboard, power adapter, etc. Digital input-output ports general purpose can be used for receiving data from the sensors on board and subsequent processing, and to send data or making control signals to other devices, i.e. for interfacing between systems.

B. System for Flight Control and Technical Condition of the UAS, Built Using a Multi-Purpose Development Platform

The system purposes are detecting malfunctions and violations of safety regulations or performance during the flight of UAS by solving logic problems [2].

The system must be able to perform the following tasks:

- Monitoring of a multiple sensory signals and software in dynamic mode;
- Based on them to make substantial conclusions for the prevention and diagnosis of defects;
- Does not interfere and influence in any way the flight software, on hardware, and not hinder to other computing devices on board.

The flight control and technical condition system must be able to ensure the proper functioning of the aircraft and alarms at issue in the main control, has the ability to constantly monitor the sensors, software and hardware components for detection and diagnosis of malfunctions and disturbances of the safety rules or productivity during the flight of UAS. [3]

Fig. 2 shows the architecture of the system for flight control and technical condition, built using a multifunctional platform development. A system contains sensors, a multifunctional platform for a development, platform for the collection and processing of data, platform for interaction with other systems on board and link with ground stations.

Multi-purpose development platform has the task to manage as initialization of the sensors and the flow of information received from them. Through its programs provide development platform will check for the accuracy of the data, sorts the data received record them in a database, sends them to the user in appropriate type and interact through a common bus interface with other systems onboard of the UAS. In this way provides user access to chronologically recorded data and transmits data in real time with the relevant connection between them, e.g. the amendment of speed, altitude, direction, etc., for a certain period of time. By suitable graphic or web interface development platform provides real-time data on remote distance via GSM module and the telemetry. The main task of the GUI is to enable the user to review the data, preparation of reports, notice of problems on board, building a statistical graphs and tables with data recorded by the system [4].

The system has all the features of flight computer and control of sensor payloads. The individual components are connected by a common bus interface and work on C/C++ architecture that provides a component-based plug-and-play infrastructure. Typical sensors include a sensor for barometric pressure, airspeed indicator, GPS, and a laser altimeter to measure the height above the ground [5].

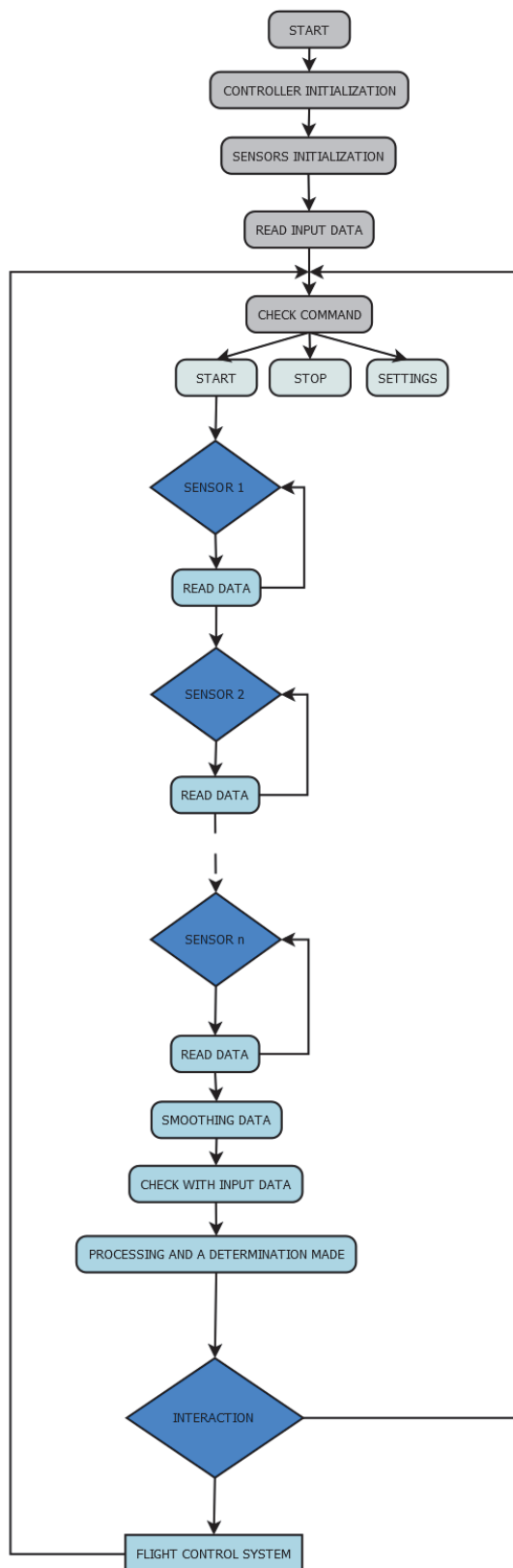

Fig. 3. Algorithm for operation of the system for flight control and technical condition for collecting and processing data from sensors onboard the UAS

The requirements of the proposed safety system operation of UAS can be categorized into the following three points:

- Control of multiple values of various parameters;
- Relationships between different systems and flight parameters;
- Control of the flight rules.

Checks for various values of the data check if they are realistic. As an example in this category includes checks on the range - for example, the maximum safe level of climb or descent. For safe operation, values should always be within certain limits. Such checks can be combined with further conditions (e.g., during the flight phase or above a minimum level) or time range (for example, the maximum succumbing from the battery current does not exceed 50A for more than 60 seconds to avoid overheating of the battery) [5].

The relationships encode dependencies between the data from the sensors, which may originate from different subsystems. For example, the measured altitude obtained from a GPS-altitude measured from the sensor for barometric pressure must be strongly connected. For another example may be indicated when a UAS is in flight [6]. Then the measured airspeed must be greater than its rate of collapse, if not greater definitely a problem.

Finally, the flight rules. Unfortunately, in Bulgaria still no regulation of the flight rules for UASs. Flight rules are defined by national and international institutions. For example, in the US there are already regulated by strict rules (Federal Aviation Administration, 2013), part 91 of the Federal Aviation (FAR)) [7], or by limitations of the systems that manage flights. For example, a rule for the minimum flight height, which must reach the aircraft after take-off is that the UAS must climb or reach a height of 600 feet within five minutes after takeoff. Similarly, it can specify time-out procedure for landing UAS. For example, after receiving a command for landing, the set command must be fulfilled within three minutes.

C. Algorithm of the System for Flight Control and Technical Condition for Collecting and Processing Data from Sensors on Board

Fig. 3 shows the algorithm of the system for flight control and technical condition for collecting and processing data from sensors on board.

After starting the device a follows initialization [8]. Initialization is performed by the controller, i.e. self-initialization and initialization on all sensors on board that directly depend on the system for flight control and monitor the technical condition of the UAS. After initialization follows read of the input data and is expected acceptance of command. Commands are three, as follows, for start, stop and system setup. For a given command start the system begins to read the data sent by sensors on board of the UAS and began to perform the functions of the system (the system functions described above in the textpoint section B). After receiving the data from sensors follows the process on the received data and the system makes the right decision. [9] The steps are as

follows filtering of the sensors data for eliminate the noise, comparing the received sensor data with the input system data, processing the received data and decision-making.

In the case of need for an interaction of the system for flight control and technical condition of UAS with the other sub-system on the board of the UAS i.e., in this case, the system for flight control. In this case, the decision taken in the form of data is sent to the flight control system i.e. to the UAV's autopilot [10].

III. CONCLUSION

This report proposed architecture and algorithm of the system for flight control and technical condition for collecting and processing data from sensors on board, built using multi-purpose development platform. They are the basis for the design and development of intelligent UAS and to develop a regulatory framework for standardization and rules for their flight. Such systems may find wide application in other areas, especially where the combined requirements for high operational reliability and service while making quick decisions. In cases of:

- Accidents and disasters, detection and monitoring of injured regions in distress;
- Agriculture for inspection of crops, search for lost animals, a wide view of the farm;
- Ecology for monitoring of flora and fauna, monitoring the condition of the areas affected by natural disasters;
- Security system to monitor large areas.

This report introduces a system that meets this requirement with the design of a real-time onboard system for flight control and technical condition capability to continuously monitor sensors and hardware components. This system can detect and diagnose failures and violations of safety or performance rules during the flight of a UAS.

ACKNOWLEDGEMENT

The proposed architecture and algorithm have been developed with the support of NIS at TU-Sofia, through participation in research projects to help graduate "System for flight control and technical condition of unmanned aerial systems" (session 2017) № 172PD0005-07.

REFERENCES

- [1] D. Musliner, J. Hendler, A.K. Agrawala, E. Durfee, J.K. Strosnider, and C.J. Paul, "The Challenges of Real-Time AI", *IEEE Computer*, pp. 58-66, 1995.
- [2] J. Schumann, O.J. Mengshoel, and T. Mbaya, "Integrated Software and Sensor Health Management for Small Spacecraft", *2011 IEEE Fourth International Conference on Space Mission Challenges for Information Technology*, pp. 77-84, 2011.
- [3] S. Poll, A. Patterson-Hine, J. Camisa, D. Garcia, D.C. Hall, C. Lee, and X. Koutsoukos, "Advanced Diagnostics and Prognostics Testbed", *18th International Workshop on Principles of Diagnosis, DX-07*, pp. 178-185, 2007.
- [4] R.A. Di Lorenzo, and M.A. Bayer, "A Prognostics and Health Management System for an Unmanned Combat Aircraft System – A Defense Acquisition University Case Study", pp.1-12, 2009.
- [5] J. Schumann, K.Y. Rozier, T. Reinbacher, O.J. Mengshoel, T. Mbaya, and C. Ippolito, "Towards Real-time, On-board, Hardware-supported Sensor and Software Health Management for Unmanned Aerial Systems", pp.1-27, 2014.
- [6] J. Schumann, K.Y. Rozier, T. Reinbacher, O.J. Mengshoel, T. Mbaya, and C. Ippolito, "Towards Real-time, On-board, Hardware-supported Sensor and Software Health Management for Unmanned Aerial Systems", pp.1-21, 2013.
- [7] Federal Aviation Administration, Federal Aviation, Regulation §91, 2013.
- [8] Y. Zhao, and K.Y. Rozier, "Formal Specification and Verification of a Coordination Protocol for an Automated air Traffic Control System", pp. 65-123, 2012.
- [9] Reg Austin, "Unmanned Aircraft Systems – UAVS Design, Development and Deployment", pp. 16-56, 2010.
- [10] D. Basin, F. Klaedtke, and E. Zalinescu, "Algorithms for Monitoring Real-time Properties", pp. 260-275, 2011.